

MIBALAJI

FOOT SWITCHES

RECOGNITION OF
Quality Plus

MINI FOOT SWITCHES



WITH GUARD



WITHOUT GUARD



WITH SHIELD



MINI FOOTSWITCH

FOOTSWITCH WITH GUARD

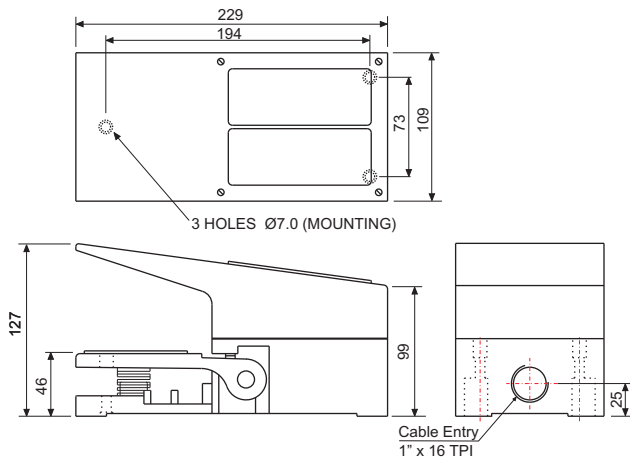

FOOTSWITCH WITHOUT GUARD

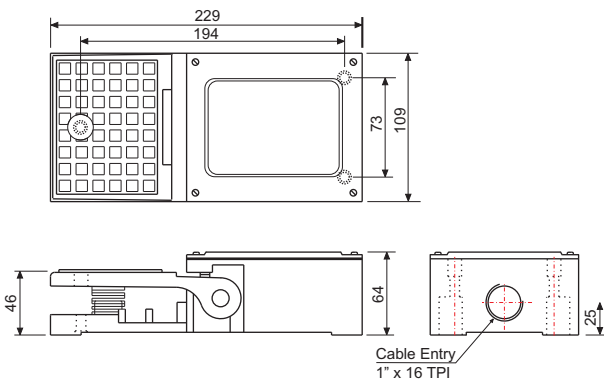

FOOTSWITCH WITH SHIELD

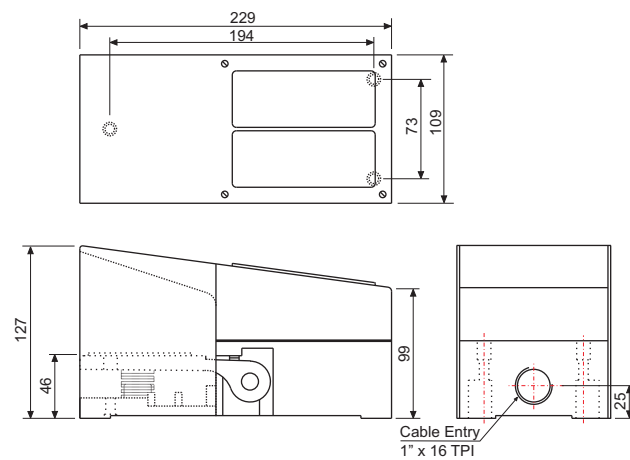

Element Characteristics

Thermal Current	10 Amps
Insulation Voltage	600 VAC
Dielectric Strength	2500 Volts per minute
Insulation Resistance	2 Meg. Ohms.
Contact Resistance	Less than 25 Milli Ohms
Short Circuit protection	10 Amps high Rupturing Capacity Fuse
Rated Impulse Voltage	1500 Volts
Utilisation Category	AC 15, DC 13
Operating force	2.70 Kg
for Mini Foot switch	
Contacts	1NO + 1NC SPDT.
Housing Material	Cast Aluminium

Electrical and Mechanical Rating

Utilisation Category : AC 15 and DC 13 as per IEC 947-5-1 and IS : 13947/Pt5/Sec-1
 Thermal current (I_{th}) : 15A
 Insulation Voltage (UI) : 600 V AC

Operational current and voltage

AC 15 rating	Single pole (1 NO + 1 NC changeover contacts)	Double pole (2 NO + 2 NC changeover contacts)
110V	4.0A	3.0A
240V	2.0A	1.5A
440V	1.0A	0.8A
600V	0.8A	0.6A

DC 13 rating	Single throw	Double throw	Single throw	Double throw
115V	2.0A	0.5A	1.0A	0.2A
230V	0.5A	0.2A	0.3A	0.1A
600V	0.1A	0.02A	0.1A	

Contact Combination : Single pole 1 NO + 1 NC changeover contacts
 Double pole 2 NO + 2 NC changeover contacts

Frequency of operation : 2500 operations per hour (max)

Mechanical and Electrical life : 20x10⁶ operations without operator
 10x10⁶ operations with operator

Operating force : 3.50 Kg

Terminal capacity : 2.5mm² solid or stranded conductors
 Housing Material : Cast Aluminium

MINI FOOTSWITCH

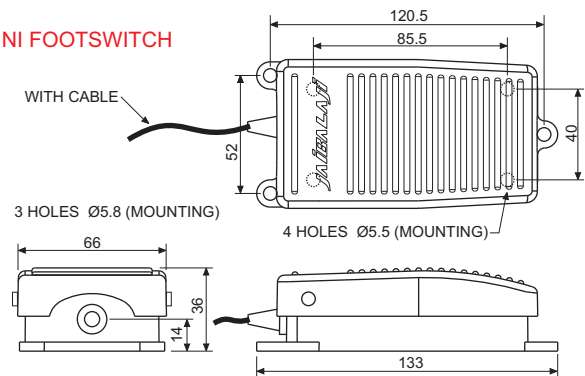

RATINGS: AC RATING INDUCTIVE-NEMA A 600

Voltage	Make		Break	
	A	VA	A	VA
120	60	7200	6	720
240	30	7200	3	720
480	15	7200	1.5	720
500	12	7200	1.2	720

RATINGS: DC RATING INDUCTIVE-NEMA P 600

Voltage	Make		Break	
	A	VA	A	VA
125	1.1	138	1.1	138
250	0.55	138	0.55	138
600	0.2	138	0.2	138

Manufactured by:



Post Box No. 27, 89 (New No. 107),SIDCO Industrial Estate, Ambattur, Chennai -600 098, India
 Phone:26251279 / 26257859 / 26254470 Fax: 0091-044-26255038. E-mail: dchandramohan@jaibalaji.firm.in

DEALERS ENQUIRIES SOLICITED